

ITEM.3 - SHAFT
 MAT. - STEEL TO BE BS 970-070 M55(EN9)
 3.2 ALL OVER U.O.S

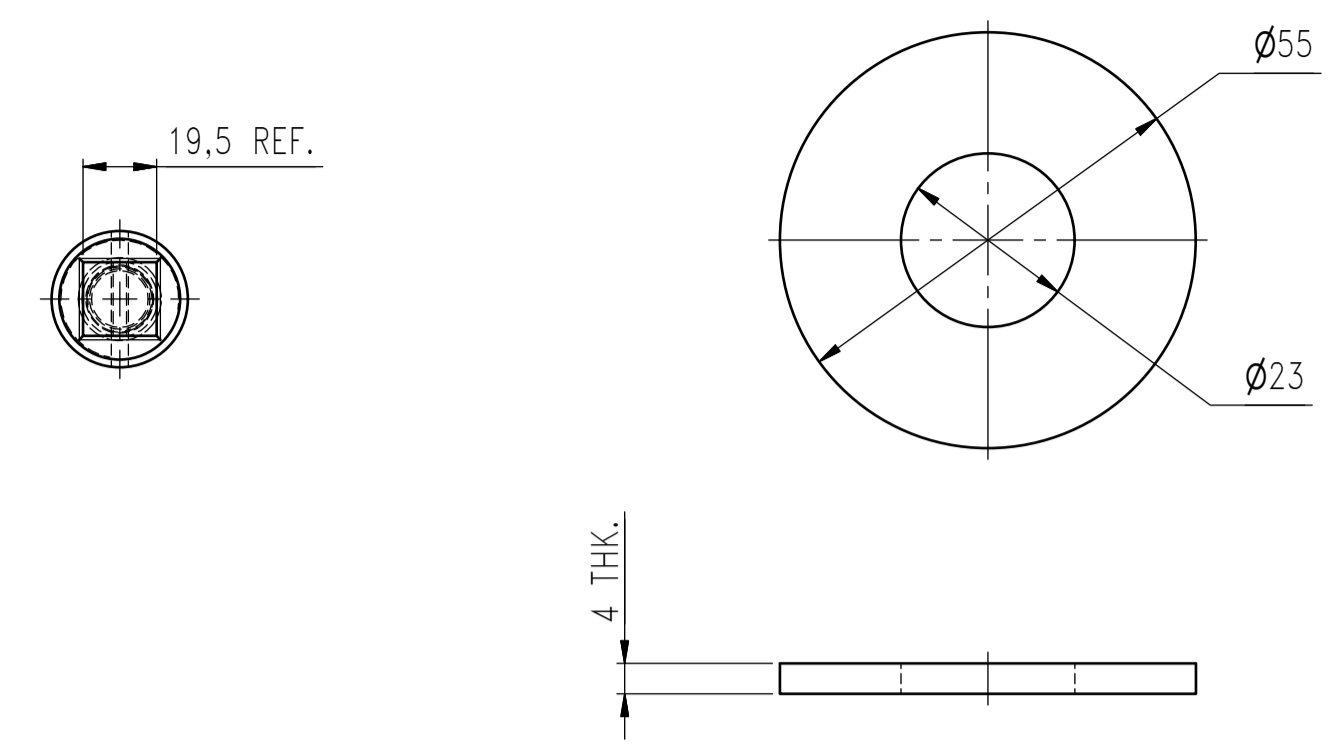

ITEM.6 - INSIDE WASHER
 MAT. - 4 PLATE

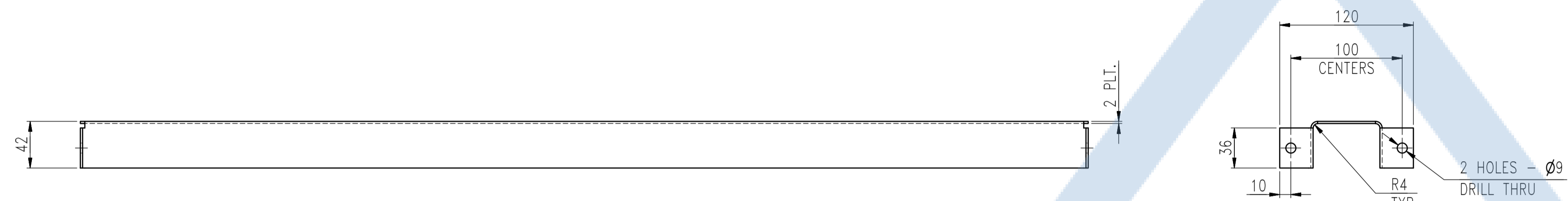

ITEM.4 - DUST COVER
 MAT. - 2 PLATE

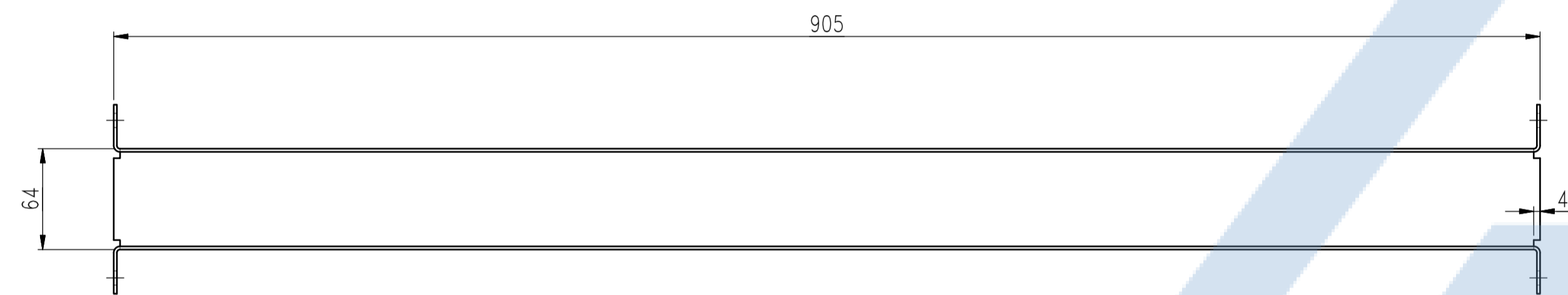

ITEM.7 - OUTSIDE WASHER 'a'
 MAT. - 4 PLATE

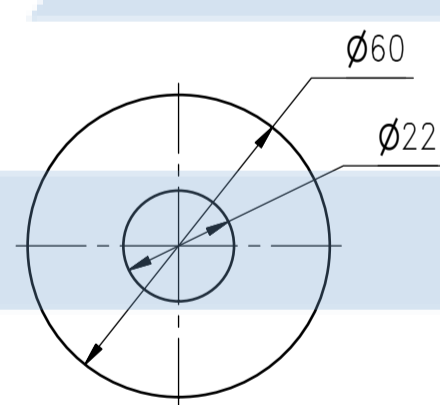

ITEM.8 - OUTSIDE WASHER 'b'
 MAT. - 4 PLATE

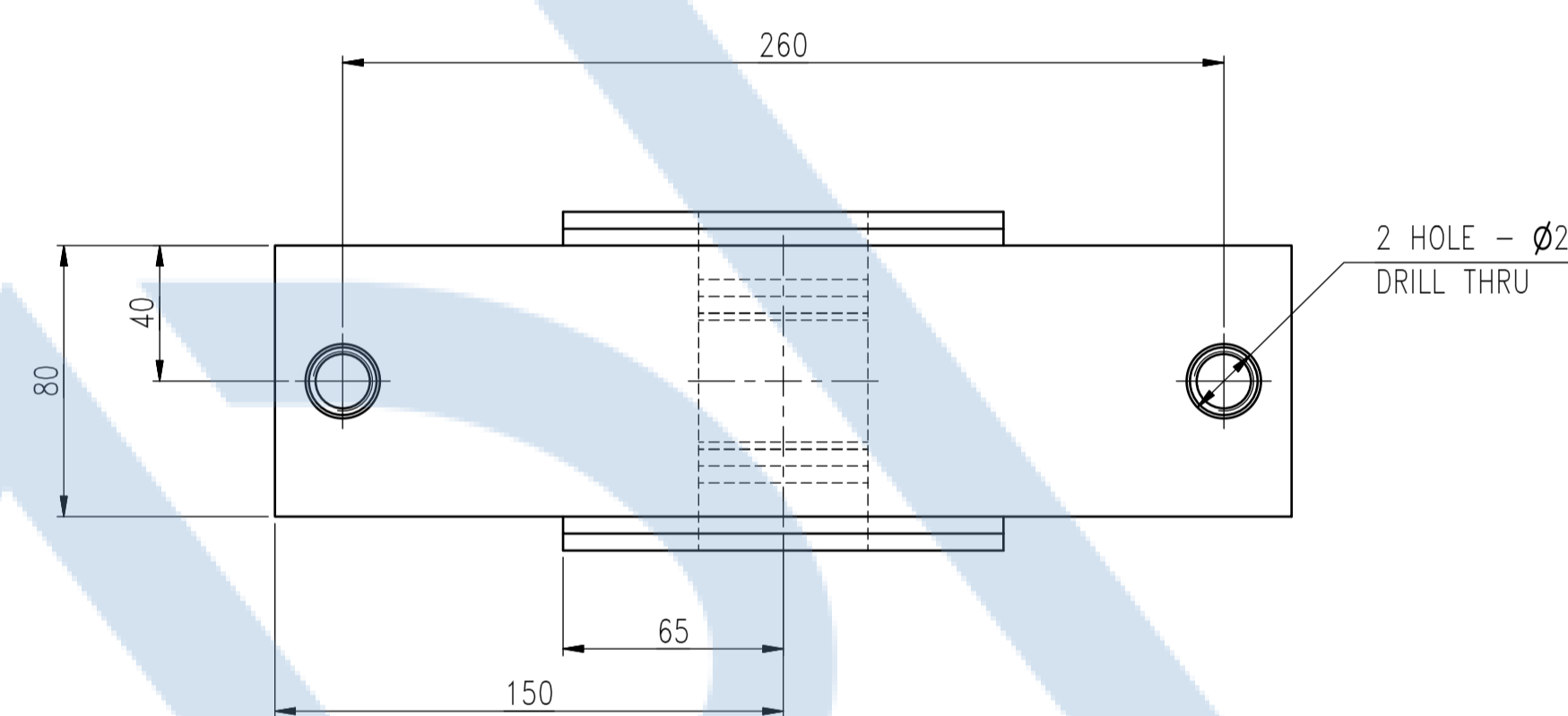

ITEM.5 - NUT
 MAT. - 10 PLATE
 ALL WELDED CONSTRUCTION

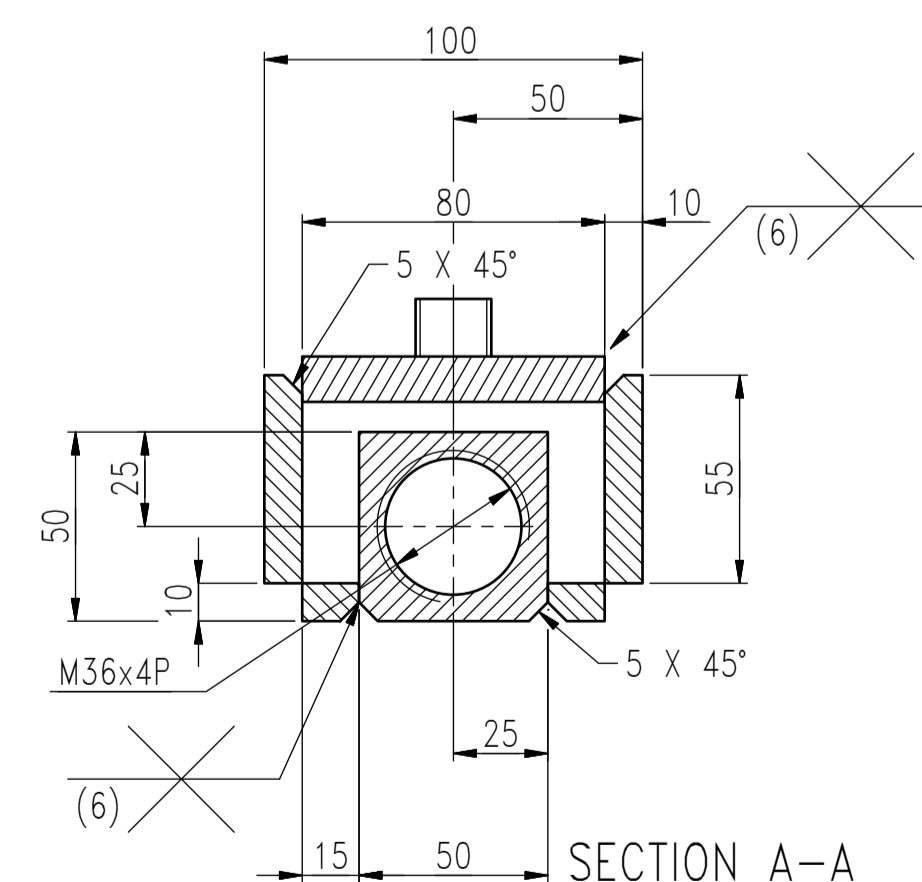
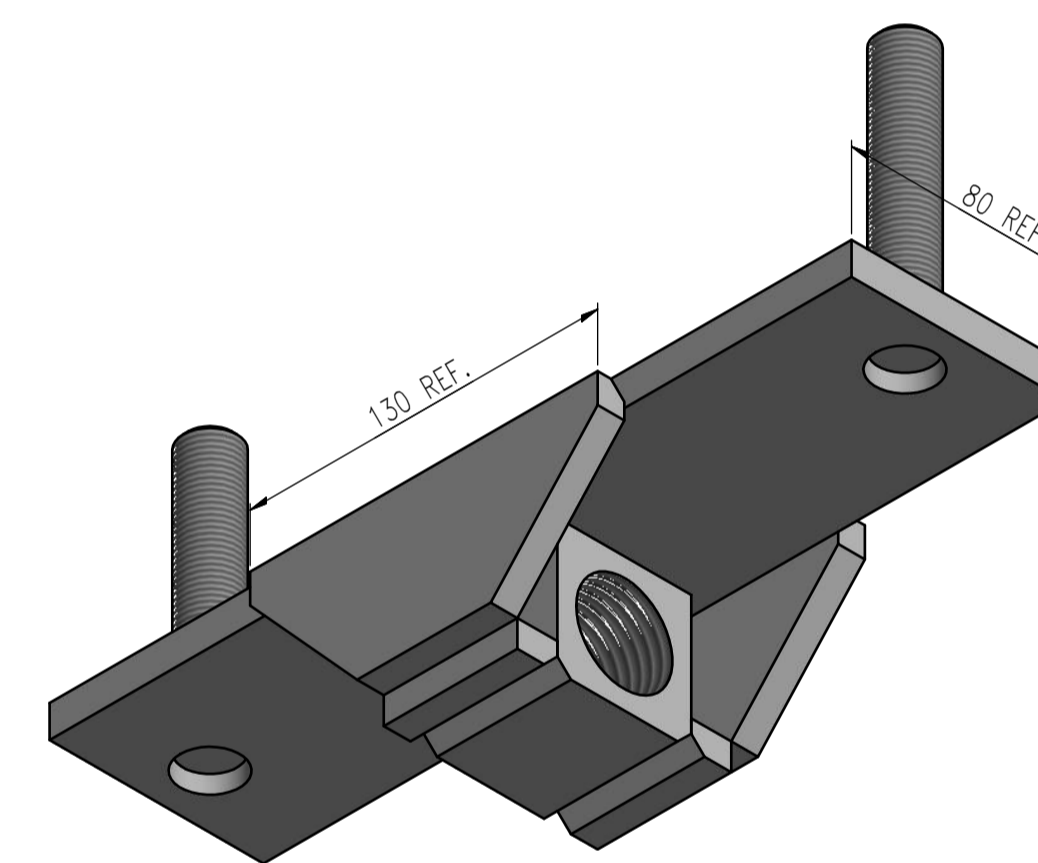

GENERAL NOTES

STRUCTURAL STEELWORK - GALVANISED

- 1: STEEL TO BE TO EN 10025 GRADE S355JR U.O.N
- 2: ALL WELDS TO BE 6 mm C.F.W U.O.N.
- 3: WELDING OF STRUCTURAL STEEL TO AWS D1.1.
- 4: ALL HOLES TO BE Ø22 HOLES FOR M20 CLASS 8.8 WITH CLASS 8 NUTS TO SANS 1700 U.O.S.
- 5: ALL FASTENERS TO BE SUPPLIED BY THE FABRICATOR.
- 6: ALL BURRS AND SHARP EDGES TO BE REMOVED.

CORROSION PROTECTION

- 1: STEELWORK SHALL BE GALVANISED IN ACCORDANCE WITH SANS 121.

IDENTIFICATION

- 1: ALL ITEMS ARE TO BE CLEARLY MARKED WITH THEIR RESPECTIVE MARK NUMBER AND THE ARRANGEMENT DRAWING NUMBER.
- 2: ALL MARK NUMBERS TO BE 12mm HIGH HARD PUNCHED MARKS.

REVISIONS		REFERENCE DRAWINGS	
REV No	DATE	DESCRIPTION	DRG No.
			SN 00 4062 SHT 1
			ARRANGEMENT

J A DRAUGHTING
 E-MAIL : jadraughting@gmail.com
 (CONTRACTOR DRAWING NUMBER)

CONTRACTOR APPROVAL		
PROFESSIONAL ENGINEER		
NAME	SIGNATURE	REG NUMBER
DATE		
CONTRACTOR MANAGER	SIGNATURE	DATE

EXAMPLE
 NOT FOR MANUFACTURE

DRAWN BY	NAME	DATE
PHATINH		2017/09/05
CHECK BY	NAME	DATE
JAH		2017/09/05

DISCIPLINE RATIFICATION		PROJECT APPROVAL	
SIGNATURE	DATE	SIGNATURE	DATE
PROCESS		ENGINEERING MANAGER	
MECHANICAL		PROJECT MANAGER	
CIVIL			
STRUCTURAL		CLIENT APPROVAL	
ELECTRICAL		ENGINEERING	
INSTRUMENTATION			
SHE		OPERATIONS	

WW9	
EXAMPLE TAIL POLLEY SCREW TAKE UP DETAIL	
SCALE	A1
SHEET 3 OF 3	REVISION 00